

PlateRite Ultima 16000N-Z/S/E **NEW**

Multi-Format Thermal Plate Recorders

High-performance CtP system
featuring industry-leading productivity,
operability and energy efficiency

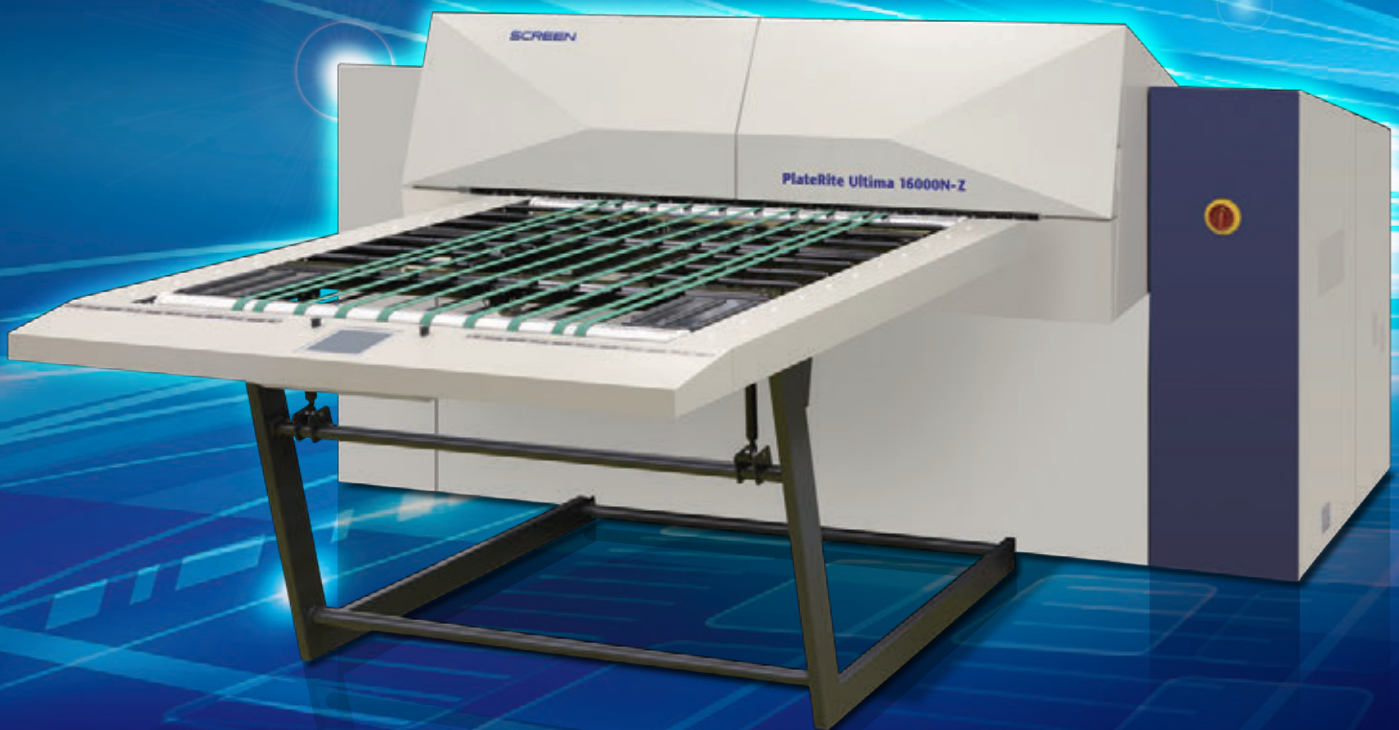

EQUIOS
ART & UX

Creating a Future in Print

PlateRite Ultima 16000N-Z/S/E

High-performance CtP system featuring industry-leading productivity, operability and energy efficiency

High Productivity

Up to **42** plates per hour

For Z model

Automation

Maximizes operating ratios

Ecology

Approx. **55%** less power use during operation

Support

Boosts operational stability

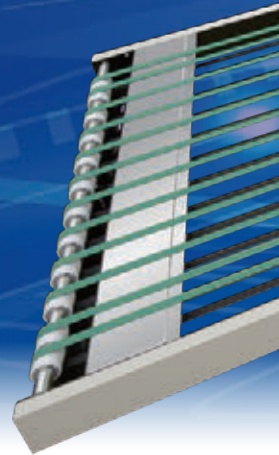

High Productivity / Industry-leading productivity enables faster turnaround

High-speed output of 42 plates per hour

Use of the latest GLV-equipped imaging heads creates significant improvements in the optical system, producing more uniform distribution of illumination. A high-precision auto-focus mechanism also allows the output of our proprietary Spekta 2 hybrid screening and Randot X 20 (20 µm) FM screening.*



The Z model is equipped with a 1,024 channel imaging head that enables the production of an impressive 42 plates per hour. The S and E models also feature 512 channel heads, with respective throughputs of up to 29 and 17 plates per hour.

* For supported plate types

Flexibility to handle a wide range of plates

A single system is able to handle plates with from four to 16 A4 pages. When fitted with the small size option, the same system can process plates right down to 450 x 370 mm (17.8" x 14.6").

System throughputs

	1,448 × 1,143	1,030 × 800
PlateRite Ultima 16000N-Z 	42	46
PlateRite Ultima 16000N-S 	29	37
PlateRite Ultima 16000N-E 	17	20

- Productivity may vary depending on the sensitivity of the plates used.
- Productivity was measured during output at 2,400 dpi, with the unit connected to an MA-L multi-cassette plate autoloader.

Automation / Autoloader system boosts press operating ratios

MA-L16000N II multi-cassette autoloader

All three models are equipped with an MA-L16000N II autoloader system that automates the entire platemaking process, from loading through imaging and transport to developing and unloading. The MA-L16000N II comes standard with three plate cassettes (up to six as an option) and full automation of both plate supply and cassette switching.

Each cassette holds up to 75 plates,* for a maximum of 450 stored in the autoloader. Even if different plate sizes are loaded into separate cassettes, the autoloader flexibly switches between the cassettes as required. This greatly extends the length of continuous operation, boosting press operating ratios and productivity as well as efficiency.

* For 0.3 mm plate

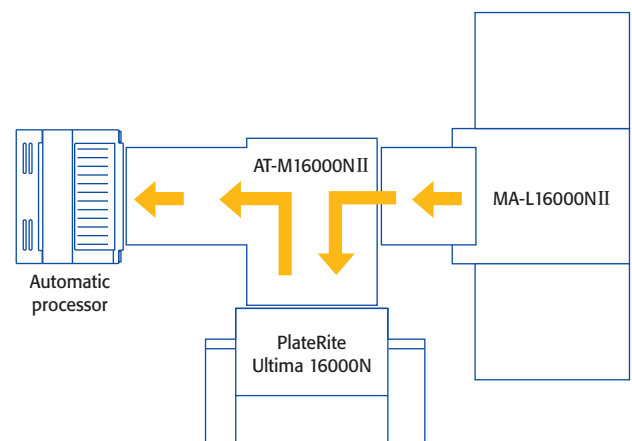



Ecology

Energy-saving design dramatically reduces running costs

Gentle on the environment

We assess the environmental impact of all our products as a form of design review. The PlateRite Ultima 16000N series has been developed with the goals of minimizing energy use and environmental impact while maximizing safety.

- Energy use during operation is reduced by up to 55%.*
- A power-saving mode allows energy savings during idling.
- Energy use during standby is reduced by up to 83%.*
- All models are compatible with chemical-less plates from a range of manufacturers.
- The use of a registration punch-less system cuts running costs.

* A comparison of the PlateRite Ultima 16000 and PlateRite Ultima 16000N-Z when a plate insertion table is used. The test involved imaging high-sensitivity material of 1,470 x 1,165 mm (57.8" x 45.8"). As power consumption is also affected by the operating environment and other external factors, the above values cannot be guaranteed.

Trends in PlateRite Ultima 16000 series electricity consumption (SCREEN measurements)

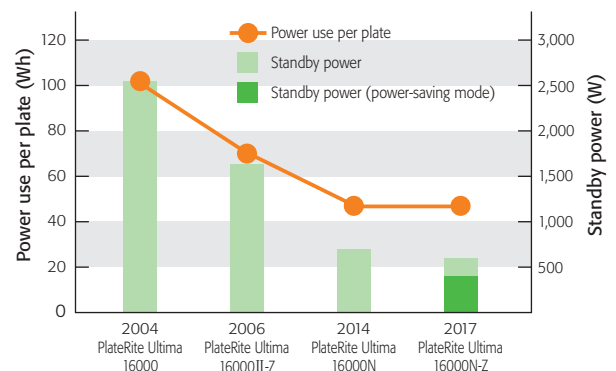

Support

Advanced support boosts system reliability

Remote monitoring function

Users can easily monitor and control their system from a remote location via Web browser or e-mail.* An external PC can also be effectively used as a substitute operation panel to manage CtP settings.

E-mails are automatically forwarded to a service center, providing an in-depth understanding of the operation status of the equipment. This information can be used during maintenance and periodic inspections to ensure the system remains in optimal condition at all times.

* Can be forwarded to up to five e-mail addresses

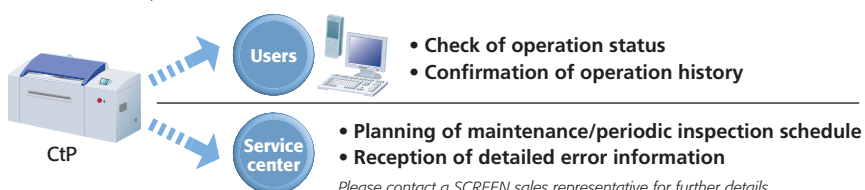

TRUST Network Service

Online maintenance support service

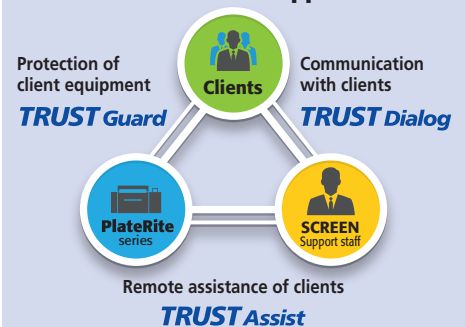

• Support for TRUST Network Service is planned.
• Please refer to the catalogue for TRUST Network Service for detailed information.

PlateRite Ultima 16000N (main unit) specifications

	PlateRite Ultima 16000N-Z	PlateRite Ultima 16000N-S	PlateRite Ultima 16000N-E
Recording system	External drum		
Light source	1,024 channel laser diode		512 channel laser diode
Plate size	Maximum 1,470 x 1,172 mm (57.8" x 46.4"); Minimum 650 x 550 mm (25.6" x 21.7")*1		
Imaging size	Maximum 1,470 x 1,172 mm [57.8" x 46.1"] (Leading edge gripper margin: 3 mm [0.12"]*1; Trailing edge gripper margin: 5 mm [0.20"])		
Plate type	Thermal aluminum plate		
Plate thickness	0.2 to 0.4 mm (7.9 to 15.7 mil)*1*2		
Resolutions	1,200*3, 2,400, 2,438, 2,540 dpi		
Repeatability*4	±5 µm		
Productivity*5	42 plates/hr at 2,400 dpi (1,448 x 1,143 mm/57.0" x 45.0" plates) 46 plates/hr at 2,400 dpi (1,030 x 800 mm/40.5" x 31.4" plates)	29 plates/hr at 2,400 dpi (1,448 x 1,143 mm/57.0" x 45.0" plates) 37 plates/hr at 2,400 dpi (1,030 x 800 mm/40.5" x 31.4" plates)	17 plates/hr at 2,400 dpi (1,448 x 1,143 mm/57.0" x 45.0" plates) 20 plates/hr at 2,400 dpi (1,030 x 800 mm/40.5" x 31.4" plates)
Press punch systems	Installation of up to 10 units		
Interface	Gigabit Ethernet		
Dimensions (W x D x H)	Main unit: 2,740 x 1,772 x 1,511 mm (107.9" x 69.8" x 59.5")		
Weight	Main unit: 1,640 kg (3,608 lb)		
Power requirements	Main unit: Single phase 200 to 240 V, 5 kW, 25 A Chiller unit: Single phase 200 to 240 V, 0.7 kW, 4 A Blower unit: Single phase 200 to 240 V, 1 kW, 10 A	Main unit: Single phase 200 to 240 V, 5 kW, 25 A Chiller unit: Single phase 200 to 240 V, 0.6 kW, 3 A Blower unit: Single phase 200 to 240 V, 1 kW, 10 A	
Environment	Recommended: Temperature 21 to 25°C (69.8 to 77°F); Relative humidity 50 to 70% Required: Temperature 18 to 26°C (64.4 to 78.7°F); Relative humidity 40 to 70%		
Options	Press punch systems (SCREEN, Heidel, Heidelberg W, Protocol, and Komori), small size option, upgrade to S model*6, air filter unit (AF-180N), signal tower unit		

*1. A minimum plate size of 450 x 370 mm and thickness of 0.15 mm (with leading edge gripper margin of 4 mm) are offered as an option. Plates wider than 590 mm and narrower than 610 mm cannot be used.
*2. With a plate thickness of 0.4 mm, only plate sizes of 900 x 770 mm and above can be used.
*3. 1,200 dpi uses doubled 2,400 dpi dots.

*4. Over four consecutive exposures on one plate at 23°C (73.4°F) and 60% relative humidity.
*5. Productivity may vary depending on the sensitivity of the plates used.
*6. For the PlateRite Ultima 16000N-E only.

Manual plate loading table specifications

Plate transport	Manual loading, manual unloading (requires interleaf paper removal)
Dimensions (W x D x H)	2,740 x 3,130 x 1,511 mm (107.9" x 123.3" x 59.5")
Weight	Approx. 1,830 kg [4,026 lb] (including main unit)
Power requirements	Supplied by main unit

Semi-automatic specifications (AT-M16000II)

Plate transport	Manual loading (requires interleaf paper removal), automatic unloading
Dimensions (W x D x H)	3,735 x 4,010 x 1,511 mm (147.1" x 157.9" x 59.5")
Weight	Approx. 2,030 kg [4,466 lb] (including main unit)
Power requirements	Supplied by main unit

6-cassette autoloader specifications (MA-L16000II + AT-M16000II)

Plate transport	Fully-automatic (automatic interleaf paper removal)
Cassette capacity	75 plates (for 0.3 mm thickness)
No. of cassettes	6 cassettes (3 cassettes each on both sides)
Dimensions (W x D x H)	6,293 x 5,520 x 1,715 mm (247.8" x 217.4" x 67.6")
Weight	Approx. 3,680 kg [8,096 lb] (including main unit and AT-M, not including plates)
Power requirements	Supplied by main unit

3-cassette autoloader specifications (MA-L16000II + AT-M16000II)

Plate transport	Fully-automatic (automatic interleaf paper removal)
Cassette capacity	75 plates (for 0.3 mm thickness)
No. of cassettes	3 cassettes
Dimensions (W x D x H)	6,293 x 3,995 x 1,715 mm (247.8" x 157.3" x 67.6")
Weight	Approx. 3,170 kg [6,974 lb] (including main unit and AT-M, not including plates)
Power requirements	Supplied by main unit

One of the specifications listed above must be selected for the PlateRite Ultima 16000N series.

www.screen.co.jp/ctp_no1

For more information, please visit our web site.
You can see product movie, MSDS on it!

Space requirements (units: mm)

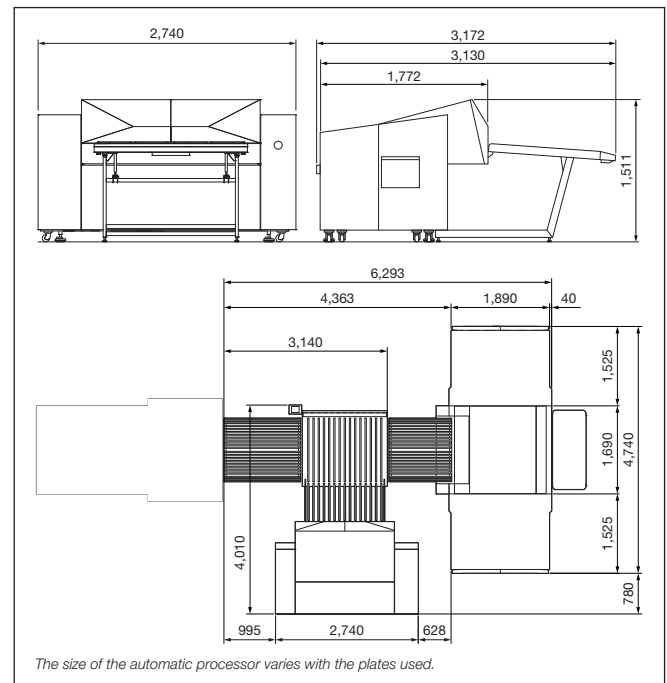

SCREEN Graphic Solutions Co., Ltd.

HEAD OFFICE

• Tenjinkita-machi 1-1, Teranouchi-agaru 4-chome, Horikawa-dori, Kamigyo-ku, Kyoto 602-8585, Japan / Tel: +81-75-414-7610

SCREEN GP Americas, LLC

• 5110 Tollview Drive, Rolling Meadows, IL 60008, U.S.A. / Tel: +1-847-870-7400 / Fax: +1-847-870-0149 www.screenusa.com

SCREEN GP Europe B.V.

• Bouwerij 46, 1185XX Amstelveen, The Netherlands / Tel: +31-20-456-78-00 / Fax: +31-20-456-78-05 www.screeneurope.com

SCREEN Holdings Singapore PTE. Ltd.

• 29, Kaki Bukit View, #02-00, Kaki Bukit Techpark II, Singapore 415963 / Tel: +65-6845-3288 / Fax: +65-6741-2168 www.screenasp.com.sg

Indian Liaison office / Tel: +91 22-6673-5088 / Fax: +91 22-6673-5087

SCREEN GP China Co., Ltd.

• Room 2001 - 2003, 20/F Cable TV tower 9 Hei Shing Road Tsuen Wan, N.T. Hong Kong / Tel: +852-2953-0038 / Fax: +852-2755-8683 www.screenchina.com

Shanghai office / Tel: +86-21-3126-5122 / Fax: +86-21-5218-2199

Beijing office / Tel: +86-10-6708-9271, 9272, 9273 / Fax: +86-10-6708-9395

Guangzhou office / Tel: +86-20-3891-1112 / Fax: +86-20-3891-1036

SCREEN GP Taiwan Co., Ltd.

• 4th Floor, No. 126-1, Min-tsu West Road, Taipei, Taiwan R.O.C. / Tel: +886-2-25862711 / Fax: +886-2-25914367

SCREEN HD Korea Co., Ltd.

• Yonsaei Bongsae B/D 10FL., 36, Chilpaero-ro Joong-gu, Seoul, 04512, Korea / Tel: +82-2-727-0807 / Fax: +82-2-727-0876 www.screen-korea.com

SCREEN GP Australia PTY., Ltd.

• Suite 11, 2 Ederin Park Drive, Macquarie Park, NSW 2133, Australia / Tel: +61-2-9016-3400 / Fax: +61-2-9016-3425 www.screenaustralia.com

Internet web site : www.screen.co.jp/ga

www.screenusa.com

www.screeneurope.com

• This brochure was made using SPEKTA 2 screening.

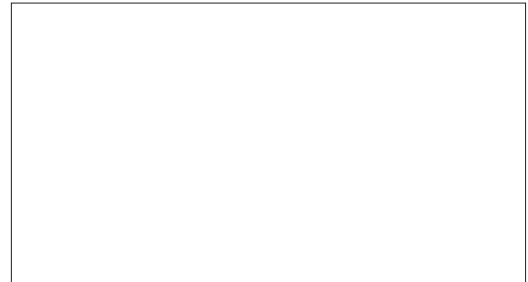

We reserve the right to alter product design and specifications without prior notice.

No.205-185E Printed in Japan 08-17 040TeSi(R0-0)